

INJECTION BLOW MOLDING MACHINE

MSZ70 注吹中空成型机

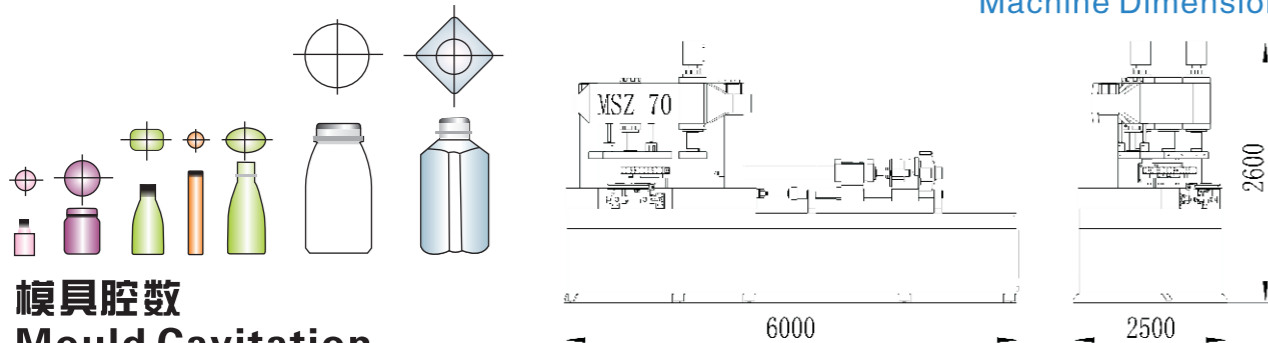

设备尺寸
Machine Dimension



模具腔数 Mould Cavitation

腔数 No. Of cavities	4	6	9	12	13	16	18	20
口径 Neck Diameter(mm)	45	40	35	35	30	25	20	10
瓶身直径 Body Diameter	80	60	50	45	40	30	25	20
最大高度 Max. Height(mm)	220	180	140	100	80	60	50	40
最大容积 Max. Volume(ml)	1000	400	200	100	60	30	20	15

仅供参考, 实际腔数依客户提供的瓶型而定。
Only for reference, based on bottle shape.

技术特点 Technical features :

- 注塑、吹塑两工位全部采用三缸锁模结构, 开合模速度快, 生产周期短、效率高。
Both perform and blow station use 3-cylinder clamping unit, mold open speed high, production high capacity .
- 伺服双油路液压驱动系统, 控制精准, 节约能耗25%以上。
Dual hydraulic system with servo pump drive, more precision control on clamping, and energy saving more than 25%.
- 卧式注射, 塑化稳定, 操作方便。
Horizontal injection design, plasticating reliable and easy operation .
- 三角横梁结构刚性高稳定性好。
Triangular beam make the structure strong and more stable performance.



选配 Optional:

- 伺服回转, 回转定位精度高。
Servo rotation device: improve rotate positioning accuracy.
- 电预塑, 可实现同步预塑。
Electric preplastication, can be synchronization in plasticising.
- 气动翻转, 安全洁净。
Pneumatic stripping plate, safe and clean.
- 直线导轨射台, 阻力小, 精度高。
Linear guide beam, small resistance, high precision.

主要技术参数 Main Technical Parameters

注射机构	Injection system	Unit	MSZ70	
螺杆直径	Screw Diameter	mm	50	55
螺杆长径比	Screw L/D		23:1	23:1
最大注射量 (HDPE)	Injection weight (HDPE)	g	298	360
螺杆转数	Max. screw speed	rpm	10-235	
机筒加热功率	Heating capacity	KW	10.8	
合模系统	Clamping & blowing system			
注塑锁模力	Clamping force of injection	KN	750	
吹塑锁模力	Clamping force of blowing	KN	89	
最大模板尺寸	Max. Platen size (L×W)	mm	800×390	
最小模具厚度	Min. Mold thickness (H)	mm	280	
模具加热功率	Heating capacity of mould	KW	6	
脱模系统	Stripping system			
脱模行程	Stripping stroke	mm	270	
空运转时间	Dry cycle	sec	3.5	
驱动系统	Driving system			
驱动电机	Motor power	KW	30	
系统压力	hydraulic pressure	Mpa	15	
制品尺寸范围	Product range			
制品容积	Suitable bottle range	ml	5-800	
制品高度	Max. bottle height	mm	≤200	
制品直径	Max. Dia. of bottle	mm	≤100	
其他	Others			
压缩空气压力	Min. Air pressure	Mpa	1.0	
压缩空气排量	Discharge rate of compressed air	M³/min	≥0.8	
冷却水流量	Water flowage	M³/h	5	
额定总功率 (含模具加热)	Total rated power with mold heating	KW	46.8	
设备尺寸	Dimension(L×W×H)	M	4.06x1.8x2.45	
设备净重	Net weight	ton	9	